



Entwicklung eines Lamellenschräglärers

Development of a baffle plate thickener

Beispielzeichnungssatz Demonstration drawing set

Ansprechpartner

Herr Gottwald:

Tel.: +49 (2943) 50198 57
Fax: +49 (2943) 50198 56
Mobil: +49 (176) 32246503
eMail: l.gottwald@plan-eta.de

Herr Müller:

Tel.: +49 (2941) 743 99 51
Fax: +49 (2941) 843 98 24
Mobil: +49 (171) 7227039
eMail: j.mueller@plan-eta.de

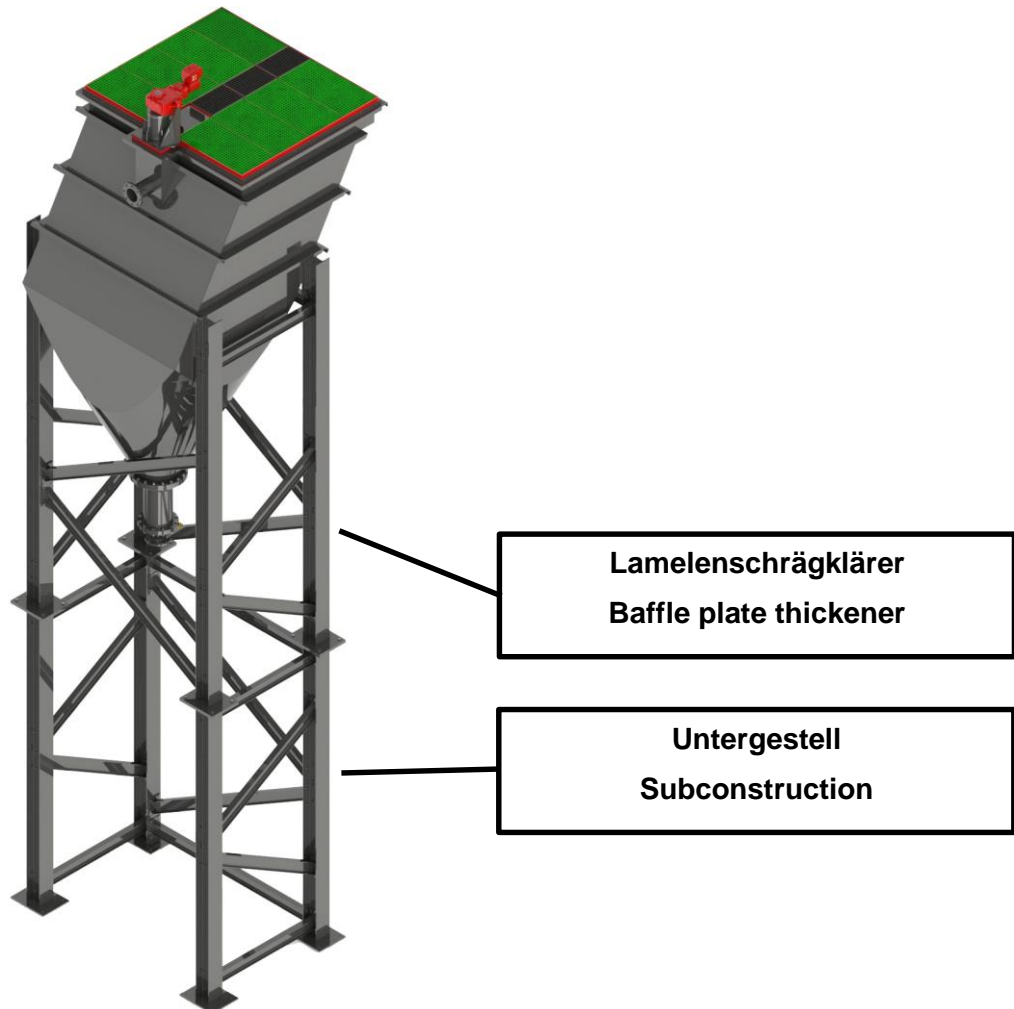

Anhang:
Seite 2: 3D-pdf Lamellenschräglärer
Seite 3: 3D-pdf Untergestell
Seite 4: Detailzeichnung Untergestell

attachements:
Page 1: 3D-pdf baffle plate thickener
Page 2: 3D-pdf subconstruction
Page 3: detail engineering of subconstruction

Enable 3D View

Enable 3D View

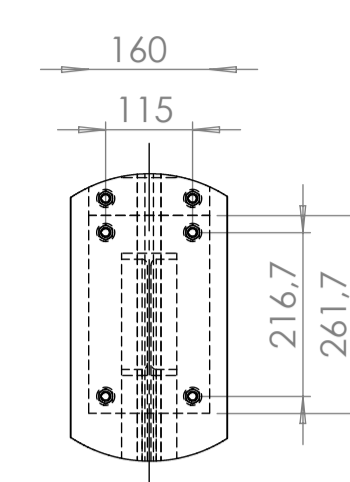
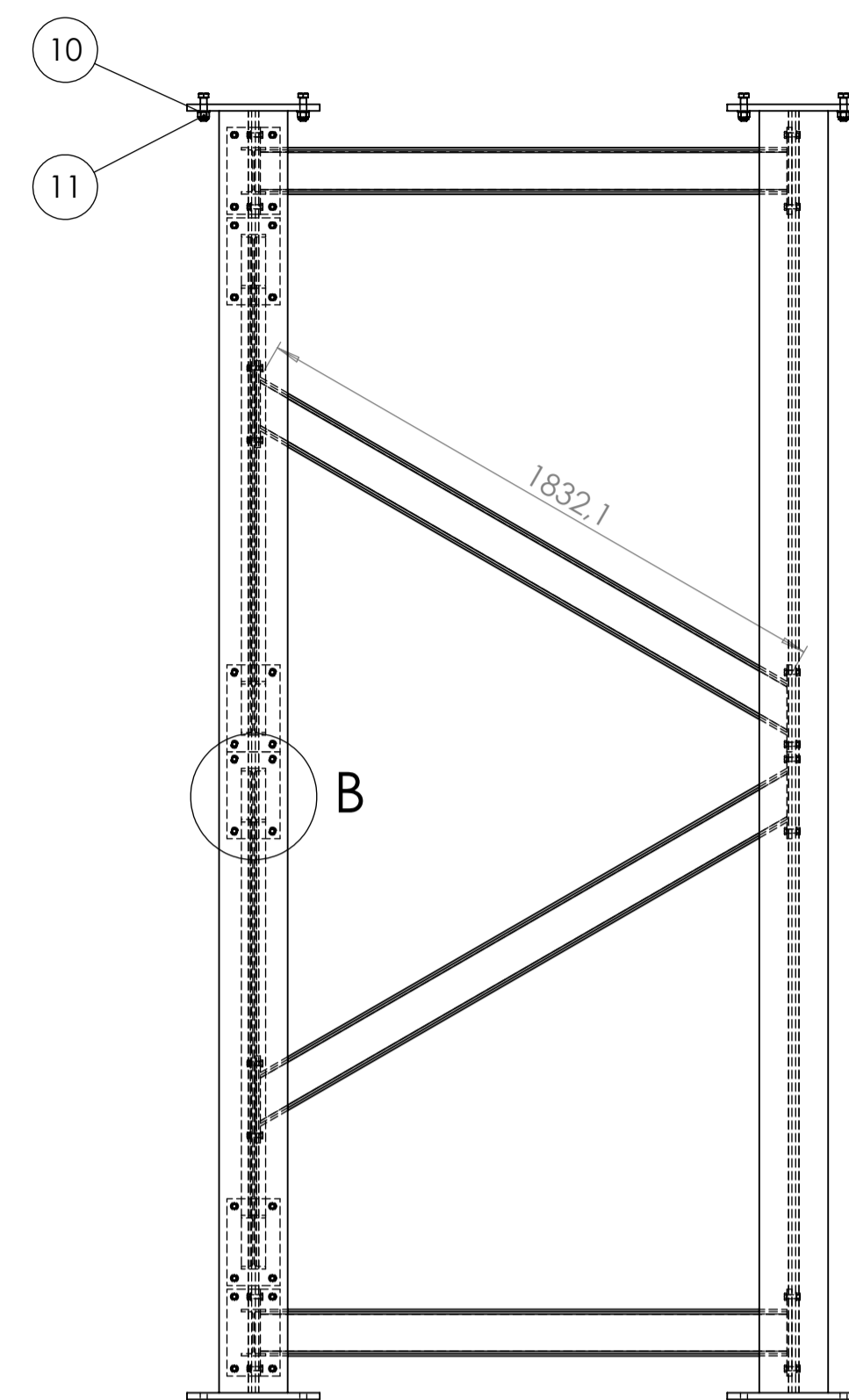
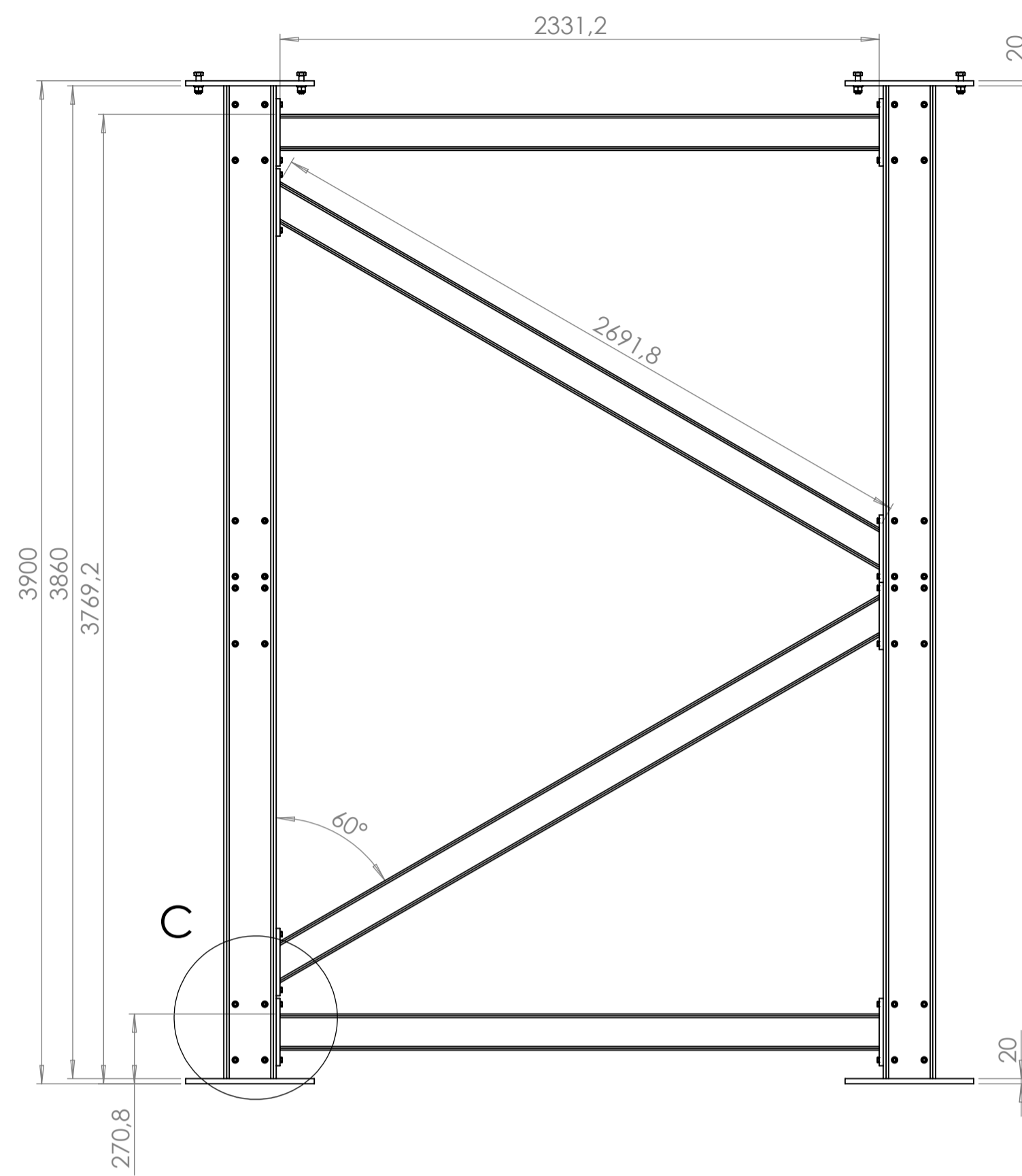

DETAIL B
SCALE 1 : 10

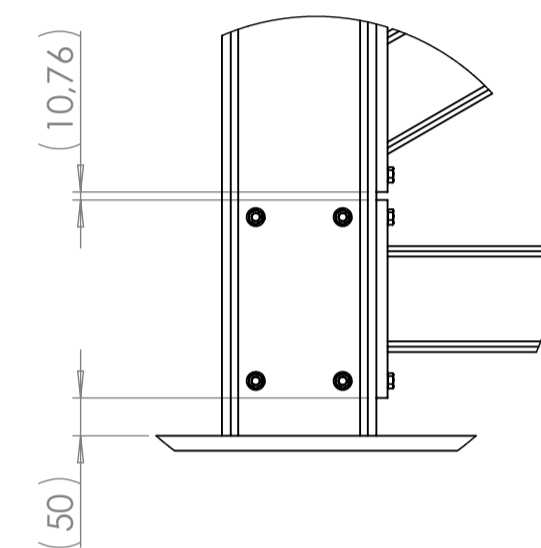

DETAIL C
SCALE 1 : 10

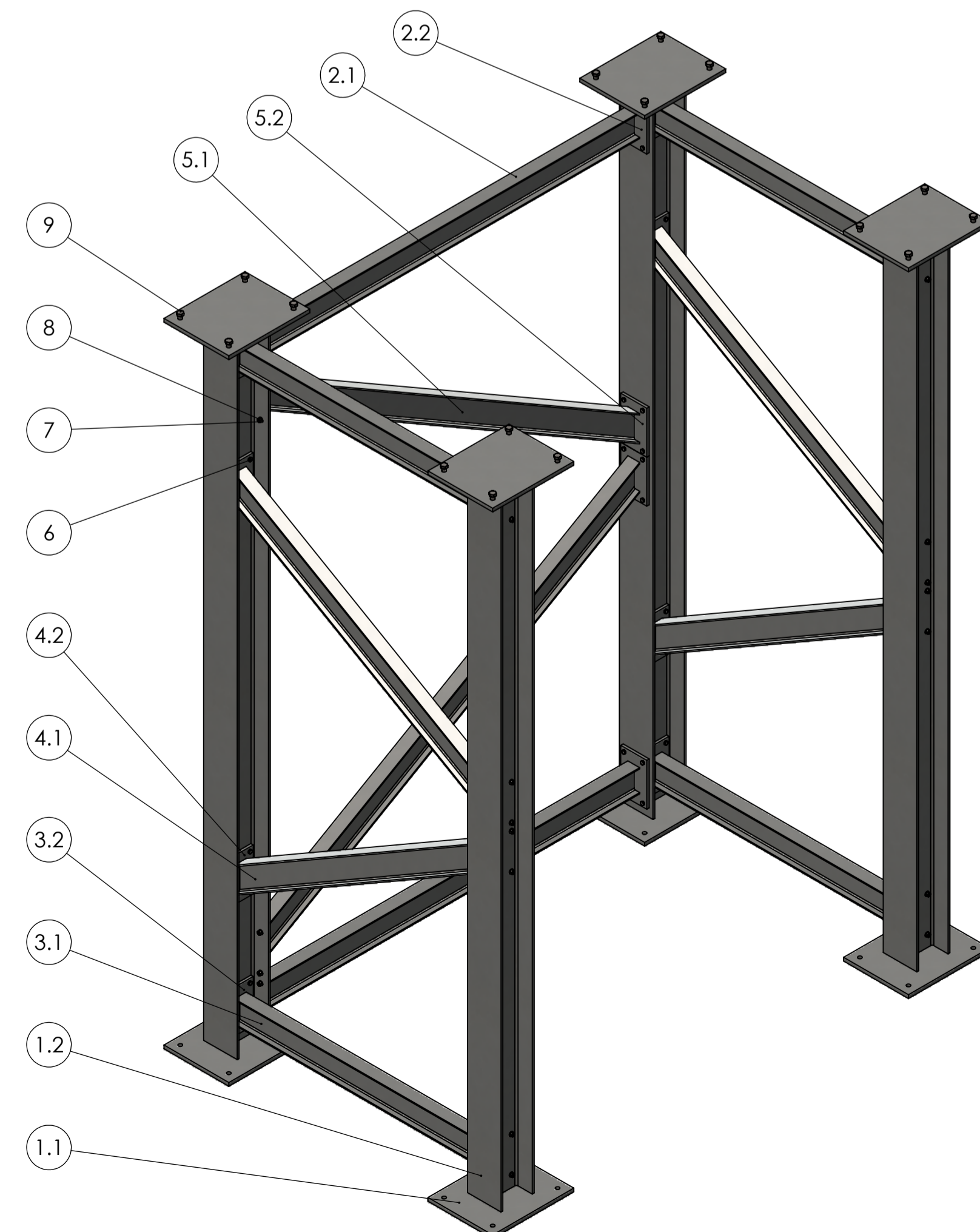
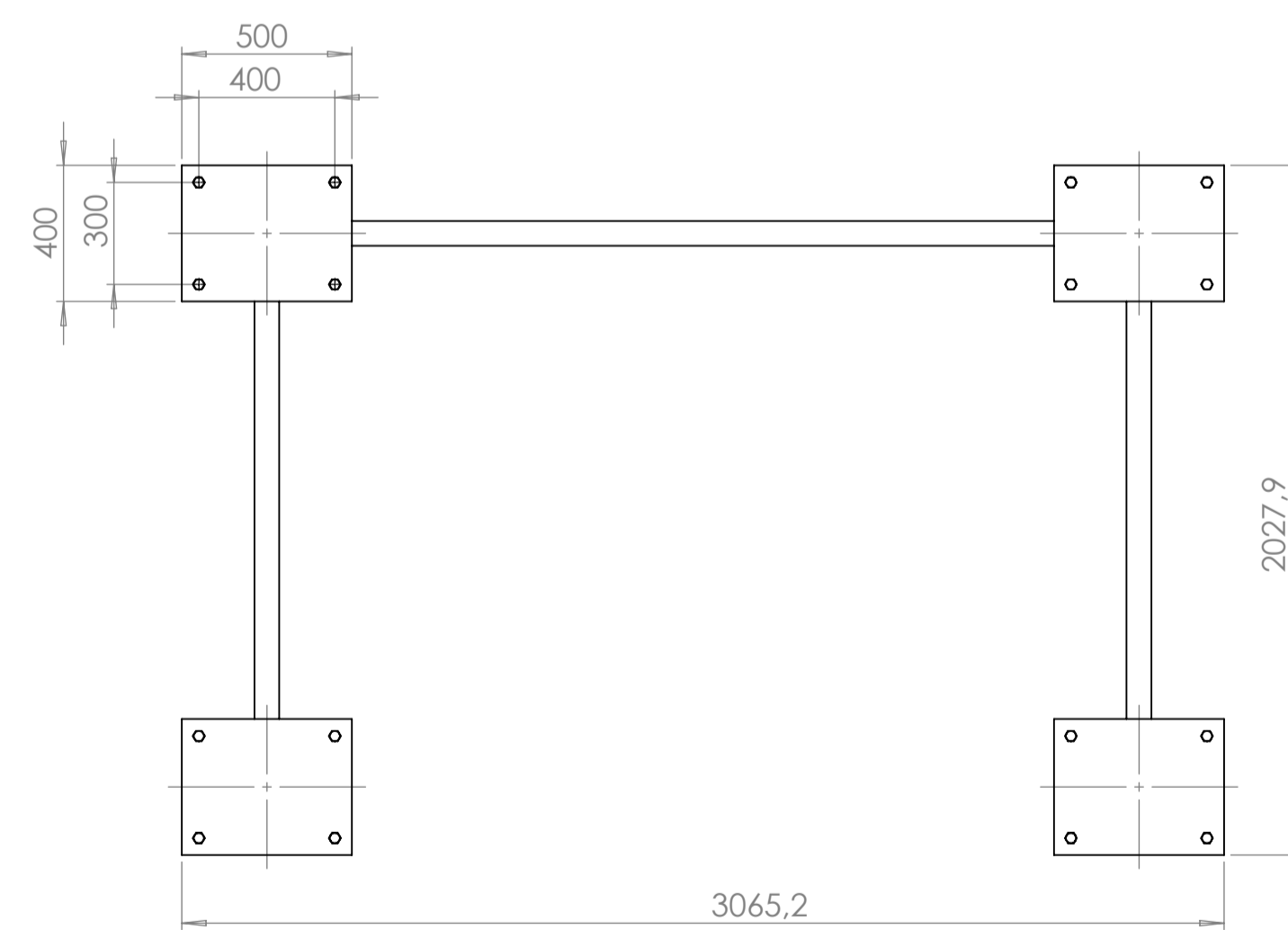

POS	QUANTITY	DRAWING NAME	MATERIAL	DETAIL DRAWING NUMBER
1	4	baffle plate thickener engagment - column complete		see below
1.1	2	baffle plate thickener - footplate		see below
1.2	1	baffle plate thickener engagment - column HP 200x200x53		see below
2	2	Baffle plate thickener - steelwork - column enstrenghment 4		not in example
2.1	1	baffle plate thickener - Steelwork enstrenghment 4 IPE 140 DIN 10025-2		not in example
2.2	2	baffle plate thickener - Steelwork enstrenghment connectionplate		not in example
3	4	Baffle plate thickener - steelwork - column enstrenghment 3		not in example
3.1	1	baffle plate thickener - Steelwork enstrenghment 3 IPE 140 DIN 10025-2		not in example
3.2	2	baffle plate thickener - Steelwork enstrenghment connectionplate		not in example
4	4	Baffle plate thickener - steelwork - column enstrenghment 1		not in example
4.1	1	baffle plate thickener - Steelwork enstrenghment IPE 140 DIN 10025-2		not in example
4.2	2	baffle plate thickener - Steelwork enstrenghment connectionplate		not in example
5	2	Baffle plate thickener - steelwork - column enstrenghment 2		not in example
5.1	1	baffle plate thickener - Steelwork enstrenghment 2 IPE 140 DIN 10025-2		not in example
5.2	2	baffle plate thickener - Steelwork enstrenghment connectionplate		not in example
6	96	ISO 4017 - M12 x 40-N		standard part
7	96	Washer DIN 125 - A 13		standard part
8	96	Hexagon Nut ISO 4032 - M12 - D - N		standard part
9	16	ISO 4017 - M20 x 70-N		standard part
10	16	Washer DIN 125 - A 21		standard part
11	16	DIN EN ISO 7040 - M20 - N		standard part

POS. 1.1
footplate
SCALE 1 : 10

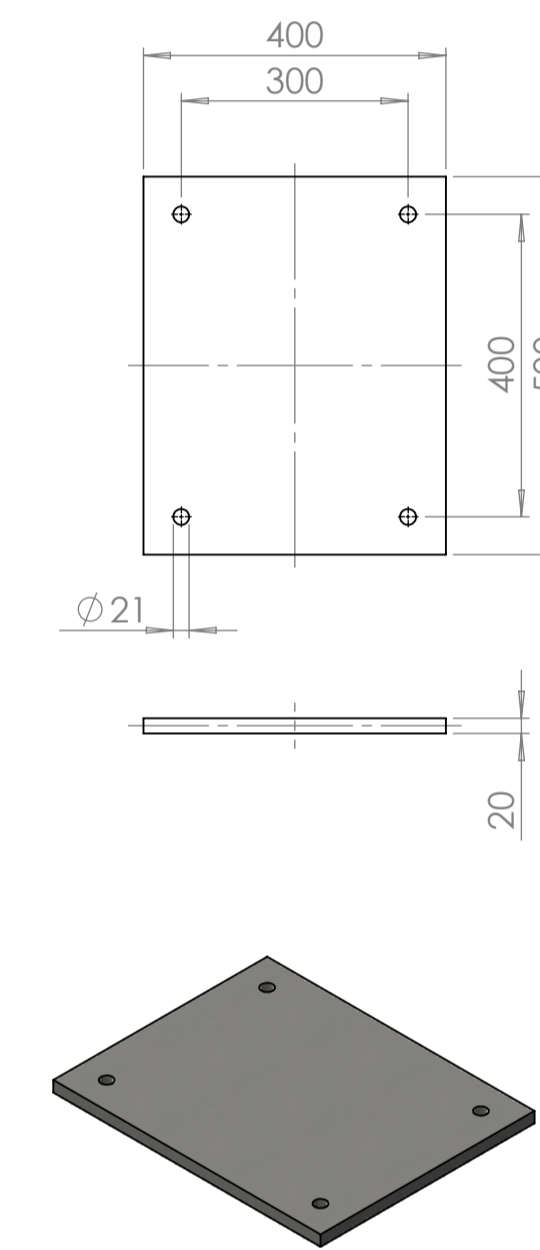

POS. 1.2
column HP 200x200x53
standard profile: HP 200x200x53
SCALE 1:20

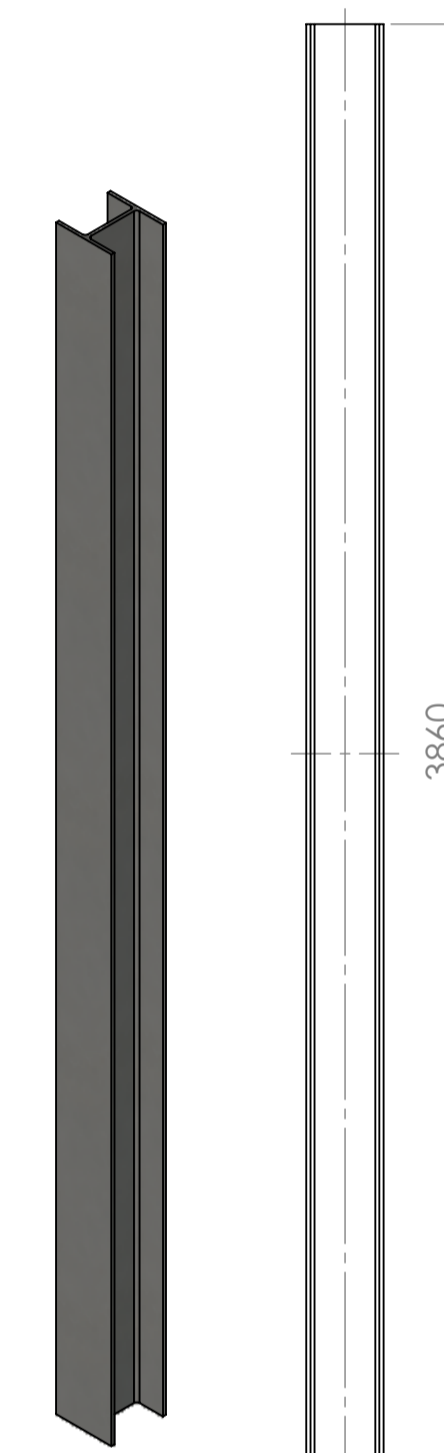

POS.1
column complete
SCALE: 1:20

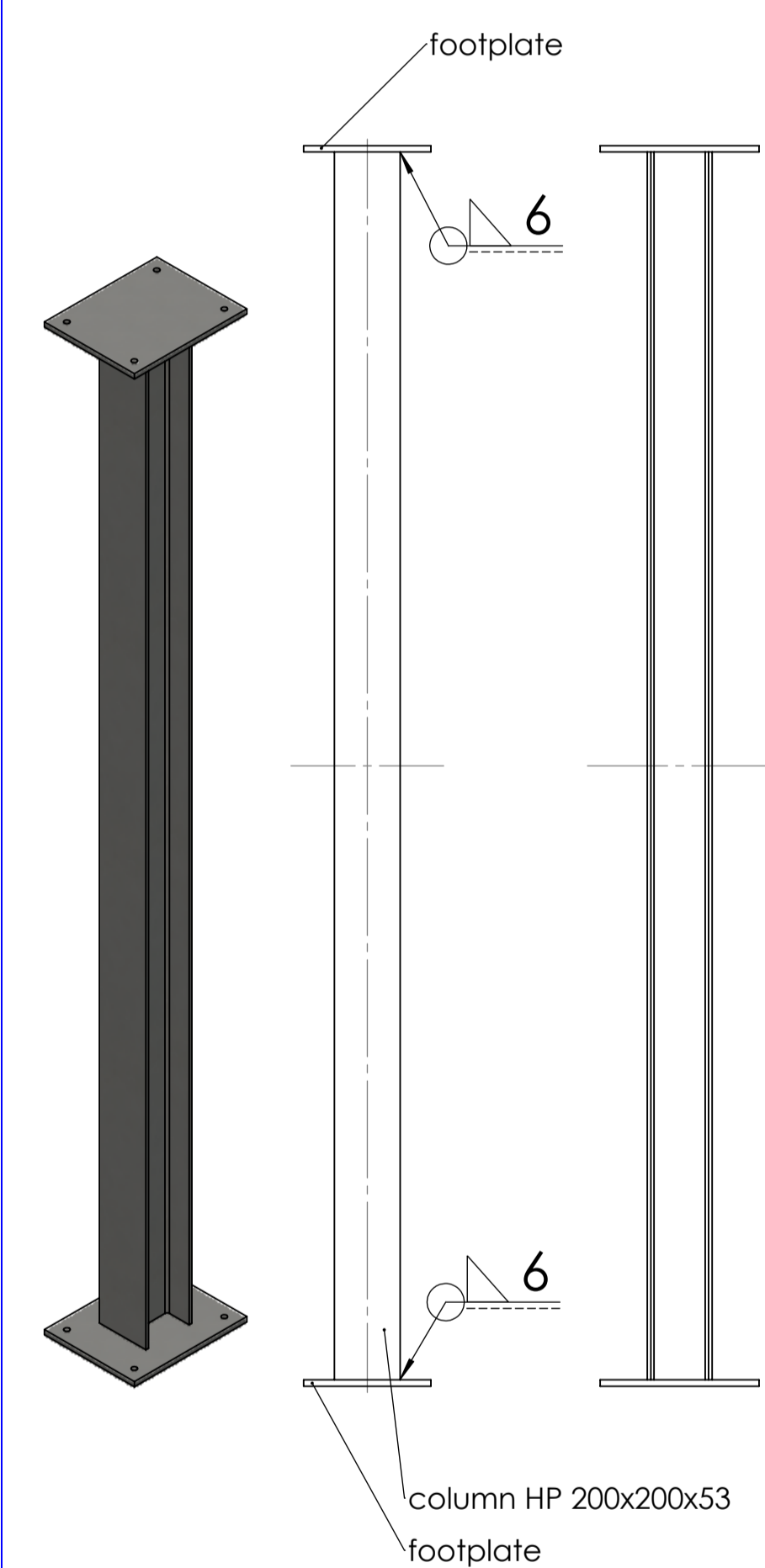

SOURCE MODEL: Baffle plate thickener engagment - complete.sldasm				
CUSTOMER:	DRAWING OWNER:	SURFACE: primed & painted	MULTIPLE SCALES	CHANGES: REV 1 (NONE)
Drawn:	NAME: JANDER	SIGNATURE: JM	DATE:	PROJECT: EXAMPLE
CHECKED:				NAME:
APPROVED:				Baffle plate thickener engagment - complete production drawing
PRODUCTION:				DRAWING NUMBER:
QUALITY:				./.
		MATERIAL:		A1
		WEIGHT: ~1,5 tons	GENERAL SCALE: 1:20	PAGE 1 OF 1